



TI-P134-50
 ST Issue 6

DCV2 and DCV3 Disc Check Valves

Description

The DCV2 and DCV3 disc check valves are of the wafer pattern designed to be sandwiched between flanges. They are suitable for use on a wide range of fluids for applications in process lines, hot water systems, steam and condensate systems etc. Face-to-face dimensions conform to EN 558 part 1, series 49. As standard they will be supplied with a metal-to-metal seat for use on steam applications. Where they are being used on oil, air, gas and water applications, alternative seat material is available - see 'Optional extras'.

Optional extras

Heavy duty springs (700 mbar opening pressure, up to DN65) for boiler feed applications.

Viton soft seats for oil, air and gas applications.

EPDM soft seats for water applications.

Standards

These products fully comply with the requirements of the European Pressure Equipment Directive 97/23/EC.

Standard shut-off

Standard valves conform to DIN 3230 part 3, BN2. Valves conforming to DIN 3230 part 3, BO3 available on request. Soft seated versions meet DIN 3230 part 3 BN1 and BO1 provided a differential pressure exists.

Certification

These products are available with a Typical Test Report. The DCV3 is also available with certification to EN 10204 3.1. **Note:** All certification/inspection requirements must be stated at the time of order placement.

Sizes and pipe connections

DN15, DN20, DN25, DN32, DN40, DN50, DN65, DN80 and DN100 Suitable for installation between BS 10 Tables 'E' and 'H', EN 1092 PN6, PN10, PN16, PN25 and PN40; JIS 5, JIS 10, JIS 16, JIS 20 flanges with the following exceptions:- DN40, DN50, DN80 and DN100 - will not fit between JIS 5 flanges DN65 and DN80 - will not fit between BS 10 'E' flanges.

Materials

No.	Part	Material	
1	Body	DCV2	Ferritic stainless steel WS 1.4313
		DCV3	Austenitic stainless steel WS 1.4581
2	Disc	Austenitic stainless steel	ASTM A276 316
3	Spring retainer	Austenitic stainless steel	BS 1449 316 S11
		Standard spring	Austenitic stainless steel BS 2056 316 S42
4	Heavy duty spring	Austenitic stainless steel	BS 2056 316 S42
		High temp. spring	Nickel alloy Nimonic 90

Note: Special testing to allow lower temperature operation can be provided at extra cost. Consult Spirax Sarco

Operation

Disc check valves are opened by the pressure of the fluid and closed by the spring as soon as the flow ceases and before the reverse flow occurs.

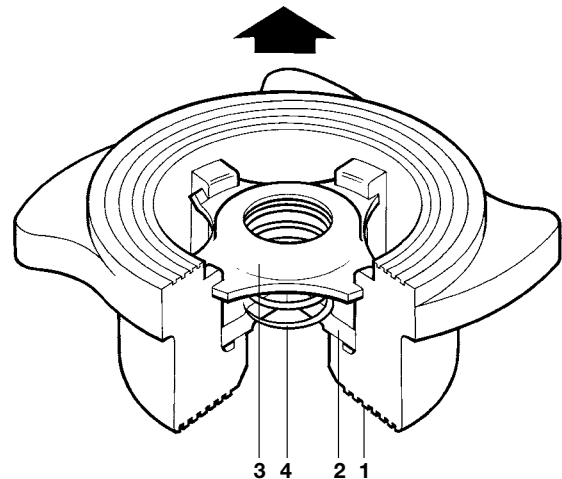
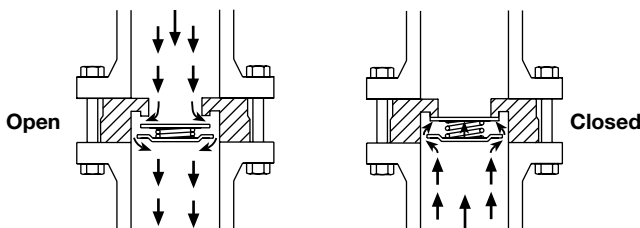

Pressure / temperature limits

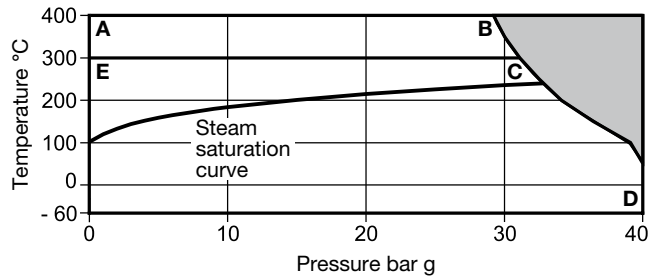

■ The product **must not** be used in this region.

A-B-D DCV3 High temperature spring and without spring.

E-C-D DCV2 and DCV3 with standard spring.

Please note: The figures displayed are only relevant when a metal-to-metal seat is used. If Viton or EPDM seats are used the product is restricted to the limits of the seat material chosen.

Body design conditions		PN40
PMA	Maximum allowable pressure	40 bar g @ 50°C
TMA	Maximum allowable temperature	400°C @ 31.2 bar g
Minimum allowable temperature		DCV2 -60°C
		DCV3 -10°C
PMO	Maximum operating pressure (metal-to-metal seat)	40 bar g @ 50°C
	Standard spring	300°C @ 33.3 bar g
	Heavy duty spring	300°C @ 33.3 bar g
TMO	Maximum operating temperature	High temperature DCV3 only 400°C @ 31.2 bar g
	Without spring	DCV2 300°C @ 33.3 bar g
		DCV3 400°C @ 31.2 bar g
Minimum operating temperature		DCV2 -60°C
Note: For lower operating temperatures consult Spirax Sarco		DCV3 -10°C
Temperature limits	Viton seat	-15°C to +250°C
	EPDM seat	-50°C to +150°C
Designed for a maximum cold hydraulic test pressure of 60 bar g		

First for Steam Solutions

Dimensions / weights (approximate) in mm and kg

Size	A	B	C	D	E	F	Weight
DN15	60.0	43	38	16.0	29.0	15	0.13
DN20	69.5	53	45	19.0	35.7	20	0.19
DN25	80.5	63	55	22.0	44.0	25	0.32
DN32	90.5	75	68	28.0	54.5	32	0.55
DN40	101.0	85	79	31.5	65.5	40	0.74
DN50	115.0	95	93	40.0	77.0	50	1.25
DN65	142.0	115	113	46.0	97.5	65	1.87
DN80	154.0	133	128	50.0	111.5	80	2.42
DN100	184.0	154	148	60.0	130.0	100	3.81

Kv values

DN	15	20	25	32	40	50	65	80	100
K _v	4.4	6.8	10.8	17	26	43	60	80	113

For conversion: C_v (UK) = K_v x 0.963 C_v (US) = K_v x 1.156

Opening pressures in mbar

Differential pressures with zero flow for standard and high temperature springs.

→ Flow direction

DN	15	20	25	32	40	50	65	80	100
↑	25	25	25	27	28	29	30	31	33
→	22.5	22.5	22.5	23.5	24.5	24.5	25	25.5	26.5
↓	20	20	20	20	20	20	20	20	20

Where lowest opening pressures are required, valves without springs can be installed in vertical pipes with bottom-to-top flow.

Without spring

↑	2.5	2.5	2.5	3.5	4.0	4.5	5	5.5	6.5
---	-----	-----	-----	-----	-----	-----	---	-----	-----

Heavy duty springs approximately 700 mbar

Pressure loss diagram

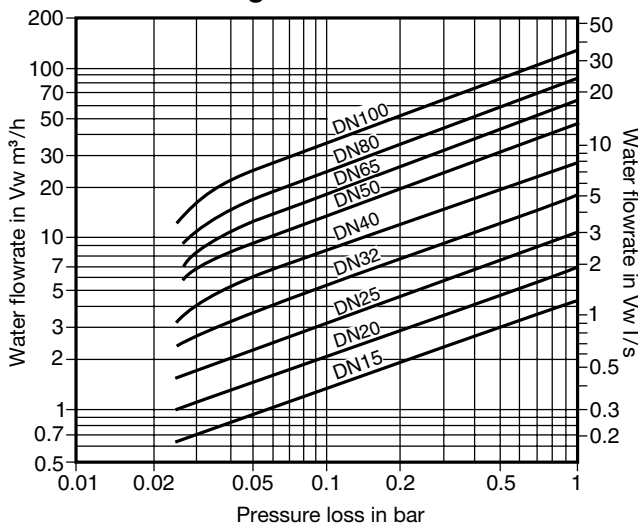

Pressure loss diagram with open valve at 20°C. The values indicated are applicable to spring loaded valves with horizontal flow. With vertical flow, insignificant deviations occur only within the range of partial opening.

The curves given in the chart are valid for water at 20°C. To determine the pressure for other fluids the equivalent water volume flowrate must be calculated and used in the graph.

$$\dot{V}_w = \sqrt{\frac{\rho}{1000}} \times \dot{V}$$

Where: \dot{V}_w = Equivalent water volume flow in l/s or m³/h

ρ = Density of fluid kg/m³

\dot{V} = Volume of fluid l/s or m³/h

Pressure loss information for steam, compressed air and gases is available from Spirax Sarco.

How to order

Example: 1 off Spirax Sarco DN50, DCV3 austenitic stainless steel disc check valve for fitting between EN 1092 PN25 flanges.

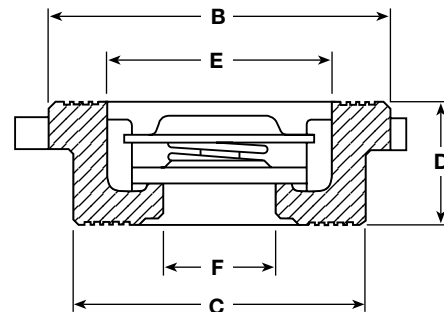
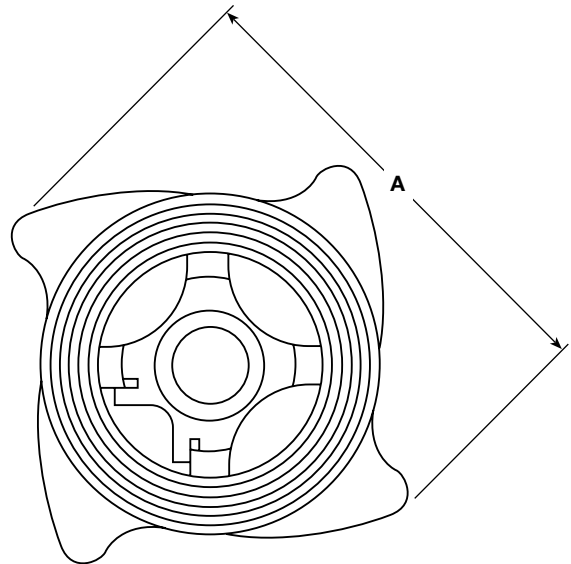

Safety information, installation and maintenance

For full details see the Installation and Maintenance Instructions (IM-P134-07) supplied with the product.

DCV disc check valves must be fitted in accordance with the direction of flow arrow indicating correct fluid flow direction. When fitted with a spring they can be installed in any plane. When supplied without a spring they must be fitted in a vertical flow line with the flow from bottom-to-top.

The 'cam' design of the body allows the various flange types to be accommodated. The body is rotated to touch the flange joint bolts ensuring that the valve is centred in the pipeline.

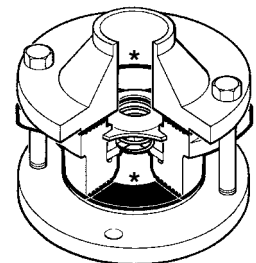

* **Note:** Flanges, bolts (or studs), nuts and joint gaskets are to be provided by the installer. Disc check valves are non-maintainable (no spares are available). Disc check valves are not suitable for use where heavily pulsating flow exists, such as close to a compressor.

Various options are denoted by a marking on the valve body:-

- 'N' – High temperature spring – Standard metal disc
- 'W' – Without spring – Standard metal disc
- 'H' – Heavy duty spring – Standard metal disc
- 'V' – Standard spring – Viton soft faced disc
- 'E' – Standard spring – EPDM soft faced disc
- 'WV' – Without spring – Viton soft faced disc
- 'WE' – Without spring – EPDM soft faced disc
- 'HV' – Heavy duty spring – Viton soft faced disc
- 'HE' – Heavy duty spring – EPDM soft faced disc
- 'T' – Valves tested to DIN 3230 part 3, B03

No identification indicates a standard spring with a metal disc.

Disposal

If a product which contains a Viton component has been subjected to a temperature approaching 315°C or higher, then it may have decomposed and formed hydrofluoric acid. Avoid skin contact and inhalation of any fumes as the acid will cause deep skin burns and damage to the respiratory system. Viton must be disposed of in a recognised manner as stated in the Installation and Maintenance Instructions (IM-P134-07). No other ecological hazard is anticipated with the disposal of this product providing due care is taken.