



Cert. No. LRQ 0963008

ISO 9001

spirax sarco

S5

Carbon Steel Separator

TI-P023-11
ST Issue 9

Description

The S5 is a carbon steel baffle type separator used for the removal of entrained liquids in steam, compressed air and gas systems.

Optional extras

Insulation jackets are available which will increase the performance of the separator, (see TI-P138-01).

Standards

This product fully complies with the requirements of the European Pressure Equipment Directive 97/23/EC and carries the CE mark when so required.

Certification

This product is available with certification to EN 10204 3.1. **Note:** All certification/inspection requirements must be stated at the time of order placement.

Sizes and pipe connections

1/2", 3/4", 1", 1 1/4", 1 1/2" and 2"

Screwed BSP or NPT, butt weld, socket weld.

DN15, DN20, DN25, DN32, DN40 and DN50.

Flanged EN 1092 PN40 with screwed BSP drain and air vent.

Flanged BS 1560 (ANSI B 16.5) Class 150 or 300 with screwed NPT drain and air vent.

Flanged JIS 2201/KS 10K and 20K with screwed BSP drain and air vent.

Note: For larger sizes use an S7 separator. See TI-P138-03.

Pressure / temperature limits

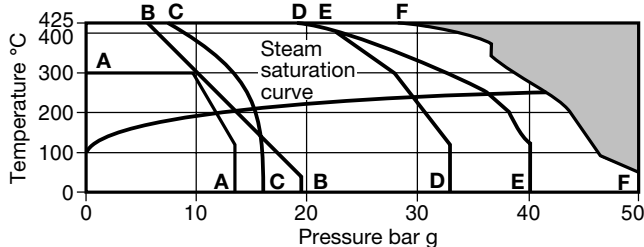

The product **must not** be used in this region.

- A - A Flanged JIS / KS 10K
- B - B Flanged ANSI Class 150
- C - C Flanged EN 1092 PN16
- D - D Flanged JIS / KS 20K
- E - E Flanged EN 1092 PN40
- F - F Flanged ANSI Class 300, screwed BSP, NPT, socket weld and butt weld

Body design conditions		PN50/ANSI 300
PMA	Maximum allowable pressure	50 bar g @ 50°C
TMA	Maximum allowable temperature	425°C @ 28 bar g
Minimum allowable temperature		-10°C

PMO	Maximum operating pressure for saturated steam service	JIS / KS 10K	12.5 bar g
		PN16	13.8 bar g
		ANSI 150	15.0 bar g
		JIS / KS 20K	30.0 bar g
		PN40	35.9 bar g
		ANSI 300	41.4 bar g
		Scrd/SW/BW	41.4 bar g

TMO	Maximum operating temperature	425°C @ 28 bar g
Minimum operating temperature		0°C

Designed for a maximum cold hydraulic test pressure of 76.6 bar g

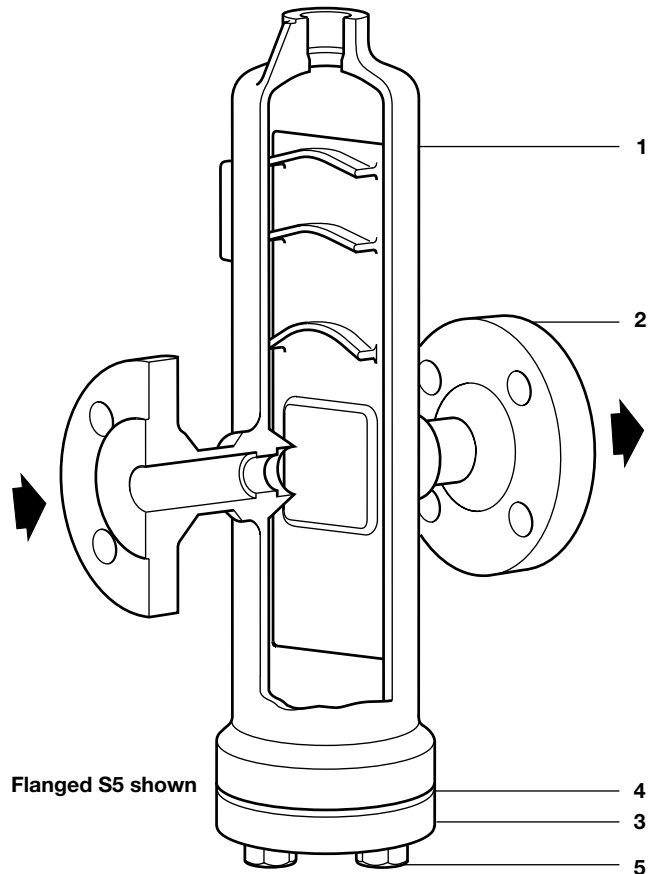

Flanged S5 shown

Materials

No.	Part	Material
1	Body	Carbon steel 1.0619 +N/ASTM A216 WCB
2	Flange	Carbon steel DIN 17243 C22.8/ASTM A105N
3	Cover	Carbon steel DIN 17243 C22.8 (1.0460)/ASTM A105N
4	Cover gasket	Reinforced exfoliated graphite
5	Bolt	Steel ASTM A193 B7

Capacities See TI-S33-06

Dimensions (approximate) in mm

Size	Screwed	PN16 A	PN40 A	ANSI 150 A	ANSI 300 A	JIS / KS 10K & 20K A	B	C	D	F	G	H
	SW, BW A											
DN15 - 1/2"	130	-	204	204	204	204	162	292	90	1"	1/2"	90
DN20 - 3/4"	130	-	212	212	212	212	158	345	90	1"	1/2"	90
DN25 - 1"	178	-	260	260	260	260	184	387	90	1"	1/2"	127
DN32 - 1 1/4"	190	-	274	274	274	274	209	438	90	1"	1/2"	141
DN40 - 1 1/2"	220	-	310	310	310	310	221	508	90	1"	1"	168
DN50 - 2"	214	-	310	310	310	310	221	558	90	1"	1"	168

Weights/volume (approximate) in kg and litres

Size	Weight		Volume	
	Scrd/SW/BW	Flanged	Scrd/SW/BW	Flanged
DN15 - 1/2"	3.3	4.5	0.84	0.85
DN20 - 3/4"	3.8	5.0	1.00	1.03
DN25 - 1"	7.0	9.5	2.50	2.60
DN32 - 1 1/4"	14.0	19.0	4.50	4.60
DN40 - 1 1/2"	22.0	27.0	7.70	7.90
DN50 - 2"	23.0	29.0	8.40	8.70

Safety information, installation and maintenance

For full details see the Installation and Maintenance Instructions (IM-P023-55) supplied with the product.

Installation note:

Install in a horizontal pipeline with the drain directly below. To ensure that any separated liquid is drained quickly, a suitable steam trap/liquid drainer must be connected to the drain connection. For those steam systems where air can be present, air can collect in the upper portion of the separator. In this situation a suitable air vent should be connected to the air vent connection. If an air vent is not being fitted then the connection must have the plastic transit protection plug removed and must have a carbon steel class 3000 lb plug fitted.

Disposal:

The product is recyclable. No ecological hazard is anticipated with disposal providing due care is taken.

How to order

Example: 1 off Spirax Sarco DN20 S5 separator with a carbon steel body flanged to EN 1092 PN40.

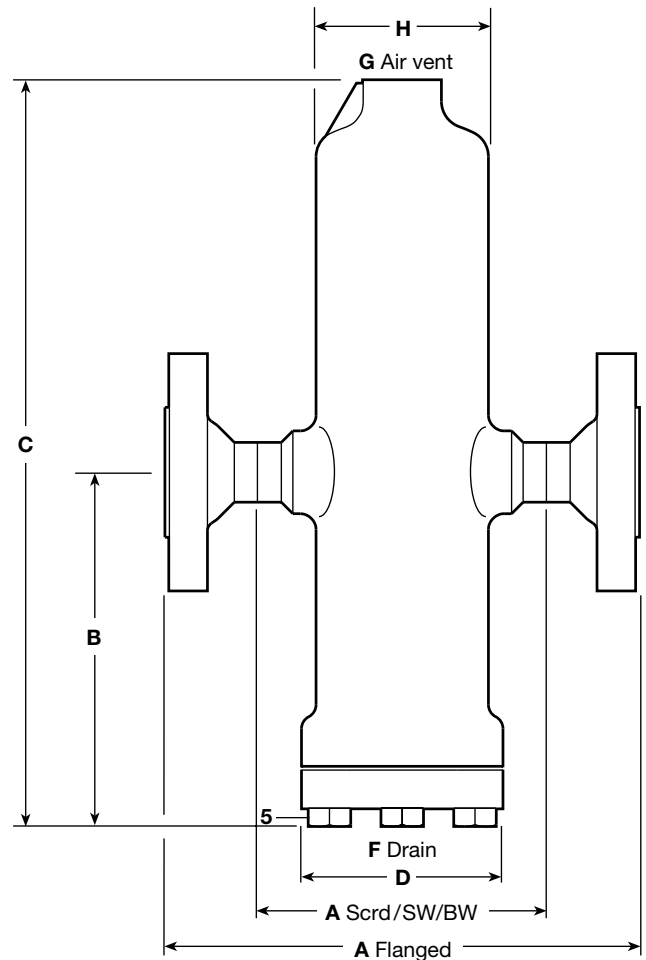

Recommended tightening torques

Item	or		N m
	mm		
5	19 A/F	M12 x 35	40 - 45