

IN15, IN25M and IN40M Steam Injectors

Description

Spirax Sarco steam injectors use steam to raise the temperature of water or other liquids. They work by using a jet of steam to draw in the liquid through radial ports, mix it, and distribute the heated liquid throughout the tank or vessel. The circulation induced by the injector ensures thorough mixing and avoids temperature stratification. Three sizes of injector are available to suit a wide range of flowrates. The smallest, the IN15, has a male and female thread for direct mounting to a tank wall from the outside, or to pipework within the tank.

The IN25M and IN40M are available with either male thread or butt-weld connection and are fitted to pipework in the tank, or to a tank wall connection.

For higher capacities, two or more injectors may be mounted in parallel.

Principal features:

- All stainless steel.
- Ideal for boiler feedtank heating and de-aeration.
- For efficient steam heating of water and other fluids.
- Heats, mixes and circulates - no moving parts.
- Compact design - minimises noise and vibration.

Pressure/temperature limits

Body design rating	PN25
Minimum operating pressure	0.5 bar g
Maximum saturated steam condition	17 bar g @ 207°C
Maximum heated liquid temperature (tank/vessel vented to atmosphere)	90°C

Materials

Austenitic stainless steel ASTM A351 CF3M.

Dimensions/weights (approximate) in mm and kg

Type	A	B	C	Weight
IN15	½"	205	28	0.4
IN25M	1"	84	71	0.8
IN40M	1½"	115	88	1.6

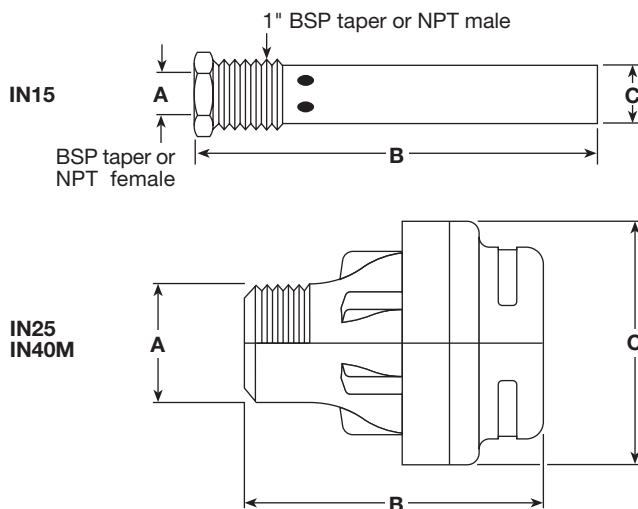

Available types

The IN15 is supplied with a ½" female and 1" male thread, available in BSPT or NPT.

Options for the larger injectors are shown below:

	IN25M	IN40M
BSPT male	1"	1½"
NPT male	1"	1½"
Butt-weld	1" Schedule 80	1½" Schedule 80

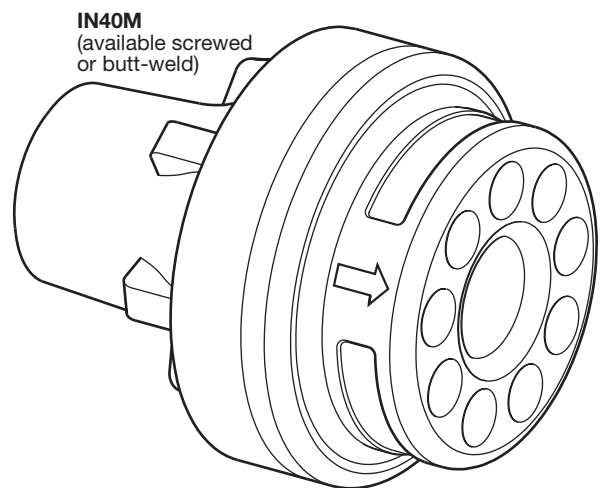

IN25M
(available screwed or butt-weld)

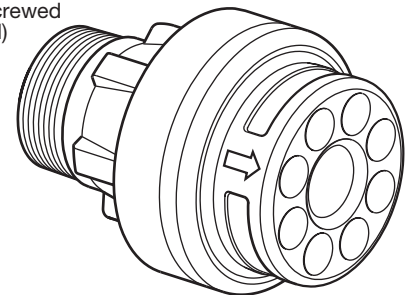

IN15

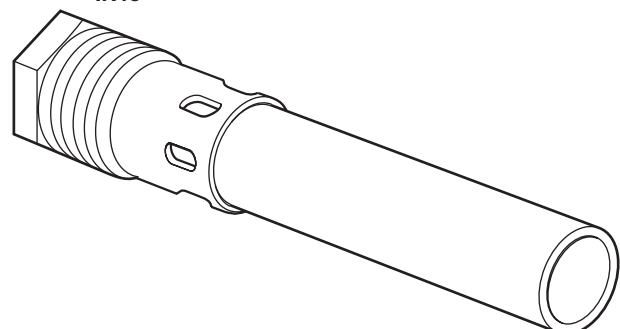

How to order

Example: 1 off Spirax Sarco IN25M steam injector having a 1" BSPT screwed connection.

Safety information, installation and maintenance

This document does not contain sufficient information to install the product safely. See the Installation and Maintenance Instructions supplied with the product.

Important:

Your attention is drawn to Safety Information Leaflet IM-GCM-10.

Installation note:

The injectors are installed at a low level in a tank, ideally along the centre line, and discharging horizontally along the length. Pipework may be routed inside or outside the tank. In all cases, steam supply pipework must be firmly anchored to prevent vibration and stress in the tank wall. We recommend the use of a suitable thread locking compound on all threaded connections.

Use the same size pipe as the injector, i.e. 25 mm pipe for IN25M. Pipe sizes for multiple injector installations are as follows:-

No. of injectors	Type	Minimum pipe size
2	IN15	20 mm
2	IN40M	65 mm
3	IN40M	80 mm

Allow a minimum of 150 mm between the injector(s) and the sides and bottom of the tank, and as much as possible between the injector outlet and the end of the tank. See the IMI for the minimum limits. Space multiple injectors equally across the tank width.

System examples

The tables below give steam capacities for some typical injector/valve/controller combinations for tanks vented to atmospheric pressure. Intermediate values may be obtained by linear interpolation. For alternatives or special applications refer to specific Spirax Sarco literature or contact our sales engineers.

The tables below are examples only, and the valve/controller combinations shown may not be available in all markets.

Note: Steam pressure at the injector will be much reduced and proper injection and mixing may not occur if a smaller valve (or larger injector) is fitted.

Capacity - selecting a steam injector

The choice of steam injector depends on the flowrate of steam required to heat the liquid. The table below shows steam injector capacities in kg/h of injected steam when heating tanks are vented to atmosphere, and are up to 3 metres deep. The choice of control valve can affect the steam capacity.

For higher capacities use two or more injectors in parallel.

Injector type	IN15	IN25M	IN40M
System pressure bar g	Saturated steam capacity kg/h		
0.5	11	75	222
1	20	135	400
2	48	175	580
3	66	280	805
4	84	350	970
5	102	410	1125
6	120	500	1295
7	138	580	1445
8	156	640	1620
9	174	700	1820
10	192	765	1950
11	210	830	2250
12	228	900	2370
13	246	975	2595
14	264	1045	2710
15	282	1095	2815
16	300	1170	3065
17	318	1225	3200

Self-acting control system examples

Injector type	IN15		IN25M	IN40M		
Number off	1	2	1	1	2	3
Valve type/size	BX6 DN15	SB DN15	SB DN20	KB51 DN25	KC51 DN40	KC51 DN50
Valve Kv	1.65	2.58	3.81	9.8	16.48	34.0
Controller type	Self-acting control with 2 m capillary Range 1. -20°C to 110°C			Self-acting control with 2 m capillary Range 2. 40°C to 105°C		
Steam supply pressure bar g	System saturated steam capacity kg/h					
2	47	82	110	350	580	1150
4	78	140	200	550	1000	1750
6	109	195	280	750	1400	2525
8	142	236	360	1000	1750	3200
10	171	310	450	1200	2075	3800
12	201	365	-	-	2500	4500
13	218	393	-	-	2675	5000

Electric or pneumatic control system examples

Injector type	IN15		IN25	IN40M		
Number off	1	2	1	1	2	3
Valve type/size	KE71/KE73 DN15	KE71/KE73 DN15	KE71/KE73 DN15	KE71/KE73 DN25	KE71/KE73 DN32	KE71/KE73 DN50
Valve Kv	1.6	4	4	10	16	36
Steam supply pressure bar g	System saturated steam capacity kg/h					
2	47	96	110	350	580	1150
4	78	168	200	550	1100	1750
6	109	240	280	750	1400	2525
8	142	312	360	1000	1750	*
10	171	384	450	1200	2075	*
12	201	456	650	1650	*	*
13	218	492	750	1750	*	*

The information given in the tables is empirical and must not be used for critical applications. Use PN5123 or EL5601 actuator, EP5 positioner (PN), SX65 controller (available with mA output for PN actuator, or VMD output for EL actuator), EL2270 sensor or pocket, and MP2 regulator.

* Consult your local Spirax Sarco sales engineer for information.